

[Browse Product Range >](#)

## Westfield Fasteners Product Specification:

### Rivet Nuts - Flat Head with Knurled Shank, Open Type

This product guide contains the specification for blind rivet nuts with a flat head, a straight knurled shank and an open end, a stock item available from Westfield Fasteners.

#### Product Description

Rivet nuts are an alternative to weld nuts, and are used for attaching a threaded hole into sheet metals and thin metal gauge parts, such as panels, tubes and castings. The riveted nut will then allow you to attach and detach mating components easily using the correct sized bolt. The larger sized rivet nuts can clamp together multiple layers of materials.

Blind rivet nuts are installed by inserting the rivet nut into the correctly sized and shaped hole within the sheet material. The rivet nut is compressed using a pneumatic powered or hand rivet nut tool, gripping it firmly to the sheet material. In the compression process, the thinner walled section without the thread collapses to form a collar on the blind side of the sheet material. This prevents the nut from being pulled back through the hole and fixes it securely to the sheet material. Like blind rivets, rivet nuts do not require access to the back of the material. Features like knurling or the hexagonal shaped body within a hexagonal shaped hole will help prevent the rivet nut from turning.

This particular type of rivet nut features a flat top, a straight knurled body and open end, and is a more common type of rivet nut. The larger diameter of the flat head will spread the load over a greater surface area, making them appropriate for most applications, including connecting soft or brittle materials to a rigid backing. The knurling/serrations will help to grip the nut to the connecting materials and stop it turning. The open end allows a bolt of any length to be used with the rivet nut, making it more vibration resistant. This type of rivet nut is used in a multitude of industries such as aerospace, automotive, rail, HVAC, white goods, electronics, DIY and general engineering.

#### Product Information

See Figure 1 and Table 1 below for dimensions for sizes from M3 to M12, along with information on sheet material thickness, pre-drilled hole sizes and strengths. Please note that head dimensions and overall length may vary between batches. Any tightening torque specifications given are guide values depending on the material of the original component and should be checked by testing.

These Rivet Nuts are produced in A2 and A4 Stainless Steel, zinc plated steel, and aluminium.

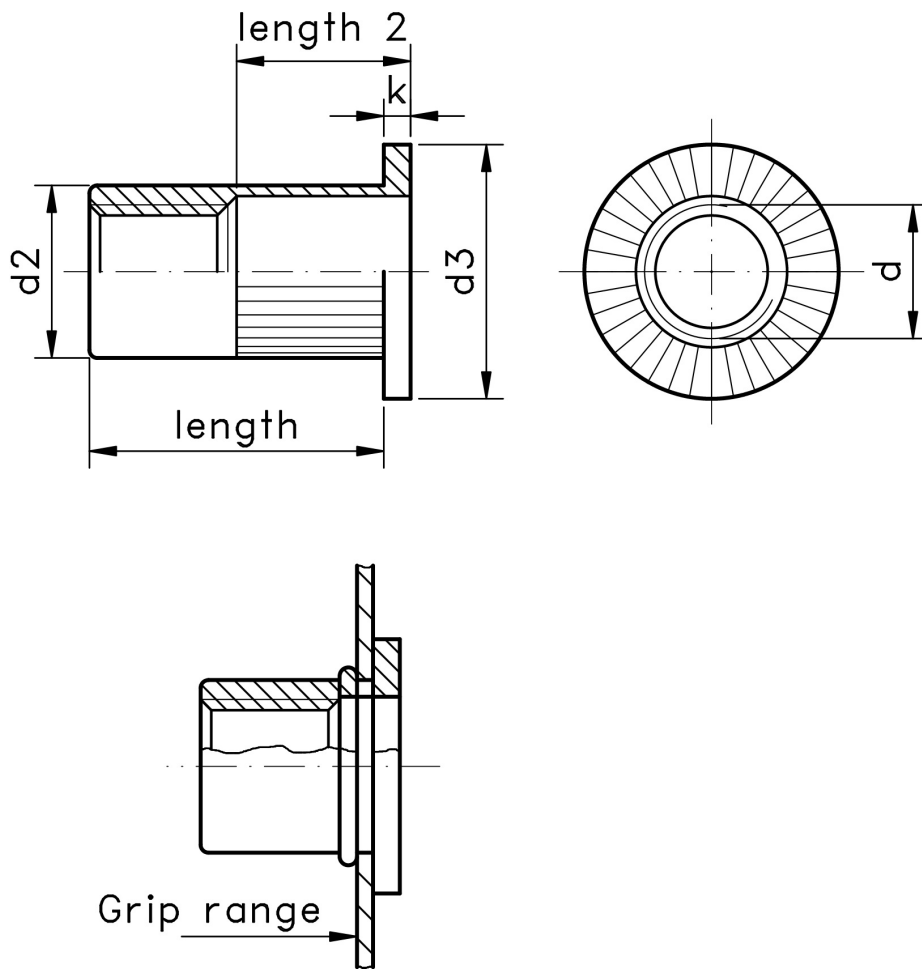

Figure 1: Rivet nuts with flat head, knurled shank and an open end

Table 1: Dimensions & Tolerances (mm) for Stainless Steel Variants

Thread, d	d1 (inner diameter)	length	d2	d3	length 2	k	Clamp Area	Drill Hole	Shear Force (N)	Tensile Strength (N)
M3	3	10	4.9	8	4.3	0.9	0.3-2.0	5	900	3900
M4	4	10	5.9	9	5.5	1	0.3-2.0	6	1500	6800
	4	11.5	5.9	9	7.5	1	2.1-4.0	6	1500	6800
M5	5	12	6.9	10	5.1	1	0.3-2.0	7	2000	11500
	5	15	6.9	10	7.7	1	2.1-4.0	7	2000	11500
M6	6	14.5	8.9	13	7.5	1.5	0.5-3.0	9	3000	16500
	6	16	8.9	13	9.5	1.5	3.1-5.0	9	3000	16500
M8	7	16	10.9	16	8	1.5	0.5-3.	11	4400	25000
	7	18.5	10.9	16	10.5	1.5	3.1-5.5	11	4400	25000
M10	10	17	12.9	19	10	2	0.5-3.0	13	5000	32000
	10	22	12.9	19	13	2	3.1-6.0	13	5000	32000
M12	12	23	15.9	23	12	2	1.0-4.0	16	6500	34000